



**QAQC LAB**

***www.qclabequipment.com***

**OPERATING INSTRUCTIONS MANUAL**



**AIR JET SIEVING MACHINE FTLBA**





## INDEX

1. Safety
2. Repairs
3. Technical specifications
  - 3.1. Description
  - 3.2. Working
  - 3.3. Characteristics
  - 3.4. Technical characteristics
4. Electrical protection IP
5. Equipment dimensions
6. Packing
7. Shipping
8. Intermediate storage
9. Standard equipment
10. Requirements for installation
11. Installation
12. Electrical connection
13. Vacuum cleaner connection
14. Working mode
  - 14.1. Preparation
  - 14.2. Weight
  - 14.3. Sieving
  - 14.4. Sieving time
  - 14.5. Work pressure
  - 14.6. Hygroscopic products
15. Keyboard description
  - 15.1. Graphic description
16. Operation mode
  - 16.1. Starting
  - 16.2. Time values programming
  - 16.3. Start / Stop sieving
  - 16.4. Indicators
17. Vacuum gage calibration
18. Maintenance
  - 18.1. Lubrication
  - 18.2. Cleaning machine
  - 18.3. Vacuum cleaner
  - 18.4. Sieves cleaning
19. Spare parts
20. Warranty conditions
21. Cyclone

## **1. SECURITY**

This operating instructions manual is aimed at everyone who works with the machine.

The air jet sieving machine FTLBA is entirely safe if you use it according with the present technical documentation.

The owner or operator has to be sure before start to work with the machine:

- That they have read and understood the entire information container in this manual.
- That they have the complete technical information of this machine.
- New personnel must have been trained by a qualified person or/with help of the present technical documentation.
- Incorrect operation can result in injuries to persons and damage for properties.
- Connect the machine to an earth wire.

We reject any claim in conjunction with injured personal or damage property due to the failure of the safety instructions implementation.

## **2. REPAIRS**

These operating instructions do not include repair instructions. For your own safety, the repairs should be made only by FILTRA VIBRACIÓN S.L. or an authorised representative (service technician).

## **3. TECHNICAL SPECIFICATIONS**

### **3.1. DESCRIPTION**

The FTLBA for the dry sieving of powder and grain products is used for obtaining sieving results between 5 and 4000 microns.

### **3.2. WORKING**

The working foundation is based on the use of air that tugs the thin particles to make it go through the sieve (picture 1). The effect is made through a vacuum cleaner that provokes a controlled decrease of pressure through the connection hole with the vacuum machine as you can see in the picture. The air sieve system FTLBA is normally supplied with a vacuum device that makes the necessary decrease of pressure to work.

## **PRODUCT BEHAVIOUR**

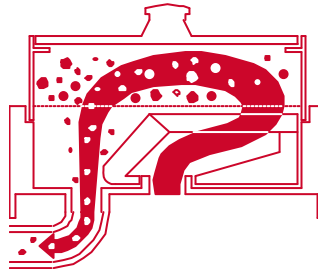

(Draw 1)

### **3.3. CHARACTERISTICS**

- Analysis range from 0,005 – 0,010 mm (depending on the product) to 4mm
- Vacuum Indicator analogical from 0 to -99 mbar.
- On/Off button
- Start/Stop button (RUN button)
- Electronic digital time programmer start, stop and interrupt at any time.

### **3.4. TECHNICAL CHARACTERISTICS**

- Reductor engine 20 rpm (19W) V= 220V - 50/60 HZ
- Vacuum cleaner: 1200 W, 220 V, 50 Hz
- Entrance protection: 2 x 8 A fuses
- Maximum vacuum values -7 kPa (-70 mbar)

## **4. ELECTRICAL PROTECTION IP**

- Electrical protection: **IP 52.**

## 5. EQUIPMENT DIMENSIONS

- Weight of the sieving machine: 20 Kg
- Total weight: 30 Kg (including packaging)
- Vacuum cleaner weight with packaging: 8 Kg

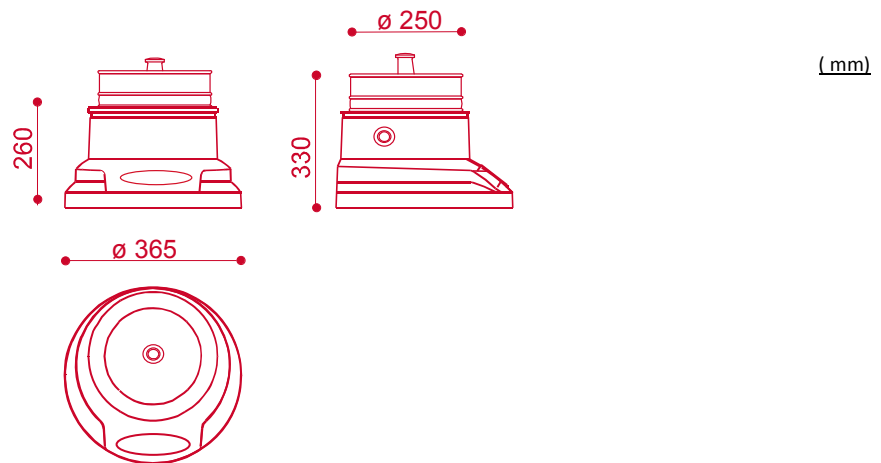

## 6. PACKING

**PLEASE, RETAIN THE PACKING UNTIL YOU GET SURE THAT THE MACHINE WORKS CORRECTLY. IF THE MACHINE HAS TO BE RESENT, THE ORIGINAL PACKING IS THE MOST SUITABLE.**

## 7. SHIPPING

During shipping, sieve shaker can't be thrown, beaten or torn otherwise the electronic and mechanical pieces may be spoiled.

## 8. INTERMEDIATE STORAGE

Ensure that the machine is stored in a dry place.  
Ensure that the machine doesn't receive any blow.

## 9. STANDARD EQUIPMENT

- Test sieve machine
- Line power cord
- Methacrilate lid
- Small plastic hammer
- Operating instructions manual
- Vacuum cleaner (optional)

## 10. REQUIREMENTS FOR THE INSTALLATION

Ambient temperature: between  $5^{\circ}\text{C}$  -  $40^{\circ}\text{C}$ .

When the ambient temperature exceeds or falls below under the specified temperature the mechanical or electronic components can be damaged.

## 11. INSTALLATION

Set up the FTLBA only in a stable surface in order to avoid unpleasant transmission of vibrations.

Isolate the FTLBA from wet surfaces due to the capacity loss during sieving process.

## 12. ELECTRICAL CONNECTION

Look to the data that are in the identification label and check that these values are corresponding to power supply.

Failure to observe the values on the data label can cause damage to either the electrical or the mechanical components or both.

## 13. VACUUM CLEANER CONNECTION

Connect the vacuum hose to the vacuum machine and to the air sieving machine (draw 2). Connect the vacuum cleaner power cord to the socket placed in the back of the machine (draw 3).

If it is necessary cut the plastic vacuum fitting to fit the vacuum regulator to the sieve shaker.





Draw 2



Draw 3

## 14. WORKING MODE

### 14.1. PREPARATION

Adjusting the suction nozzle height:

- Unscrew the suction nozzle.

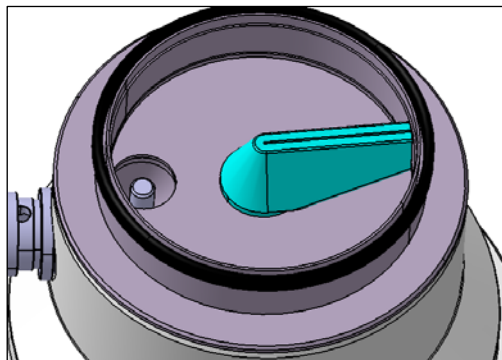

- Take out the suction nozzle to see the shaft.

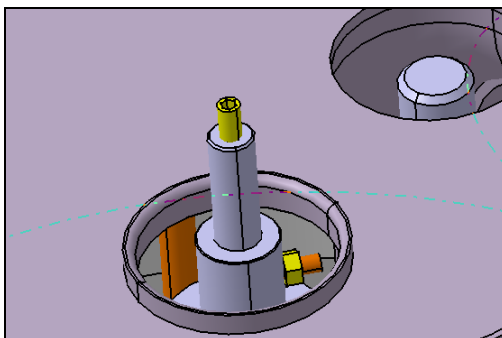

- To increase or decrease the level of the suction nozzle exist a screw which we have to screw up or unscrew to adjust.

- Once the adjustment is ready place the suction nozzle in the shaft. The aperture of the suction nozzle must be clean of product.



The standard distance between the suction nozzle and the sieve is  $2 \div 4$  mm.

## 14.2. WEIGHT

### General rule:

If there is a bigger quantity of product will have a more exactly test and more duration of the sieving.

The maximum thickness of the product particles on the sieve must be controlled. The product (all the particles) must move on the sieve when the suction nozzle is turning.

The weight must be adapted for each kind of test. Our general recommendations for sieves of  $\varnothing$  200 mm are:

- Normal situation. For sieves with 0.040 mm: 20 gr.
- For heavy products with good fluency: until 50 gr.
- Light products and materials with some difficulty to sieve and sieves with mesh under 0.040 mm: 10 gr.

## 14.3. SIEVING

To have several points in the grinding curve of the product, begin with the sieve of smaller opening mesh and sieve the product that have not passed with the immediately bigger opening. Do the same way with the other openings. Follow this procedure so many times as separations you want to have.

Sieving process:

- Place the suitable sieve.
- Weight the product to be sieve and put on the sieve.
- Place the methacrylate lid.

- Adjust the operating time and push the “run” button.
- Wait for the adjusting time programmed or stop directly and weigh the rejected product.

During the sieving process is convenient to hit the lid with the small plastic hammer to clean it of dust of product.

Eventually you can interrupt the vacuum machine and the air jet sieving machine for brake with a brush the small agglomerates of product (clod) that can be formed.

When the sieving time is over, you must weigh the material that is on the sieve. To avoid losses of material brush the surface that is in the lid and when you put the powder into another sieve brush carefully the mesh of the sieve.

#### **14.4. SIEVING TIME**

The sieving process will be finished when after a noticeable period of time there is no rejection of product on the sieve.

According with the UNE-EN 933-10, 2001 edition, the sieving time can be considered finished when the weight no changes more than 0.1 % during 1 minute.

#### 14.5. WORK PRESSURE

Fit the working pressure through the air regulator like in the picture. For decreasing the working pressure unscrew the cylinder and for increasing pressure screw it.

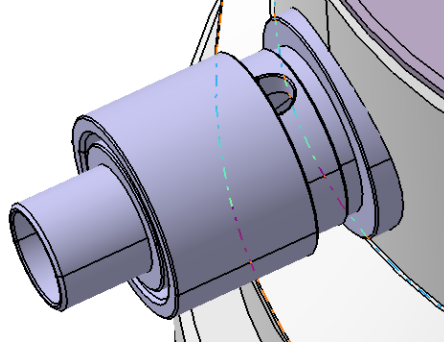

According to the standard UNE-EN 933-10, *tests for fixing the arid geometrical properties*, the working pressure recommended is  $3,0 \pm 0,5$  kPa (-30 bar). Nevertheless, we recommend that for sieving different materials you should obtain the work pressure through tests.

The excessively fragile materials (those which are easy to pulverize) must be sieved with the lowest working pressure.

#### 14.6. HYGROSCOPIC PRODUCTS

The hygroscopic products absorb air's humidity during the sieve process. So, this fact may cause some measurement's mistakes.

If you don't want to despise this mistake you should dry the product before and after each sieving process.

**15. KEYBOARD DESCRIPTION**

Keyboard: 3 tactile keys with sound warning. Every key has a different function as is described in the “function mode”.

- <+>            *Increase of the active characteristic.*
- <- >            *Decrease of the active characteristic*
- <RUN>          *Operation start / pause*

Display: It is formed by 4 high luminosity digits, size 0.3”, red colour distributed by this way:

Vacuum	2 digits showing the vacuum level selected in mbars	0 ÷ 99
Time	2 digits showing the total time operation in minutes	00 ÷ 99

The connection between the machine and the electric wire is done through a bipolar switch and a simple fuse, de 5 x 20.

**15.1. GRAPHIC DESCRIPTION**

- Keyboard frontal view

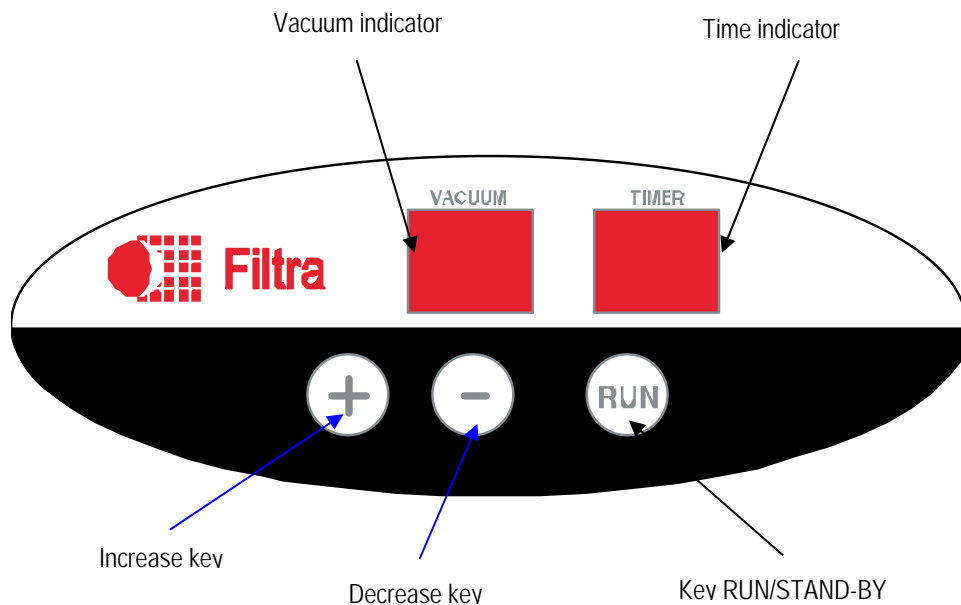

## 16. OPERATION MODE

### 16.1. STARTING

Once you switch on the machine a segments test will appear in the display. Finishing the test the machine and also de indicators start working showing the values when switched off.

### 16.2. TIME VALUES PROGRAMMING

Pressing the increase key <+> or decrease key <-> you can select its time value between 00 and 99 (minutes). It will appear two dashes (--) on the vacuum indicator showing that we are modifying the time value.

Pressing RUN key the sieving time value will be fixed.

### 16.3. START / STOP SIEVING

Pressing the RUN key, sieving will start according to the programmed values. When sieving is run, pressing the RUN key a pause is done and the clock and sieving will stop.

### 16.4. INDICATORS

The indicators show information in different ways according to the condition or function of the equipment.

- Once the equipment is connected, an internal test will be done, in order to verify the correct operation of the 4 display indicators (vacuum and time).
- Two dashes (--) in the vacuum indicator means that the time is being modified (you are in the programming sequence) through the increase key <+>, and the decrease <->.



- ▶ Two points, one in the timer indicator and the other in the vacuum indicator shows that it is a partial time: the remaining time to finish the process.
- ▶ Once the sieving is finished, this indicator returns to its normal condition, without any point activated. It shows the total time value, the programmed value.



- ▶ Two intermittent points in the timer indicator and vacuum indicator shows the remaining time to finish the sieving (partial time). The machine is in pause mode.

#### **17. VACUUM GAGE CALIBRATION**

The machine has an automatic calibration on the point 0 each time that is connected.

## 18. MAINTENANCE

### 18.1. LUBRICATION

All the bearings are lubricated for life.

### 18.2. CLEANING OF THE MACHINE

To remove the nozzle pull vertically of the nozzle.

Connect the machine and clean with a brush the nozzle, the body of the sieving machine and the inner part of the suction opening with the help of the vacuum.

**Warning: Don't turn the nozzle with your hands.**

### 18.3. VACUUM CLEANER

If the working pressure is not high enough possibly the filter of the vacuum cleaner is dirty. Open the vacuum cleaner, clean the filter or change it.

### 18.4. SIEVES CLEANING

Clean carefully the low part of the sieve with a soft brush. Don't make pressure or hit the mesh of the sieve.

The most effective method for clearing sieves is to introduce the sieves in an ultrasonic cleaner device. Ultrasonic cleaner Filtra devices are the more suitable for this purpose. To improve the effect of the ultrasonic cleaner add some detergent to the water.

If you don't have available an ultrasonic cleaner you can do it by hand. To clean the sieve put it with water and detergent and clean it with a soft brush.





## 19. SPARE PARTS

The only spare part for the FTLBA sieve shaker are the sieves.

For the vacuum cleaner there are spare parts of paper vacuum bags. There are two kinds:

- Standard bag ref. **D-200-BA/GM80**: BAGS ASP.NILFISK MOD.D-200/AS-GM80 REF.82095000 (5 units / box).
- Special bag to avoid the loss of pressure in the sieving process of products with a smaller grading: ref. **D-200-BA/GSP80H**: *BOLSAS REUTILIZABLE ASP.NILFISK MO.D-200/AS-GM80 (REF. GSP 80 H)*.

## 20. WARRANTY CONDITIONS

- The warranty of the machine is for two years since the delivery date.
- The warranty includes pieces, spare parts and labour for any repair in the installations of FILTRA VIBRACIÓN S.L.
- The warranty does not include the shipment. It has been paid by the client.
- The warranty does not include the spares of joints or sieve mesh.
- The warranty does not cover possible damages caused during the transportation and installation of the equipment.
- Repairs due to an incorrect use of the machine will not be included in the warranty.
- Any modification or manipulation of the machine without authorization of FILTRA VIBRACIÓN S.L. will invalidate the warranty.

**21. CYCLONE**

In air-jet sieves, the fine fraction is drawn by the aspirator together with the sweeping air.

When this is to be avoided and need to recover this fraction, a cyclone is inserted between the sieving machine and the vacuum cleaner, where the product is separated from the air.

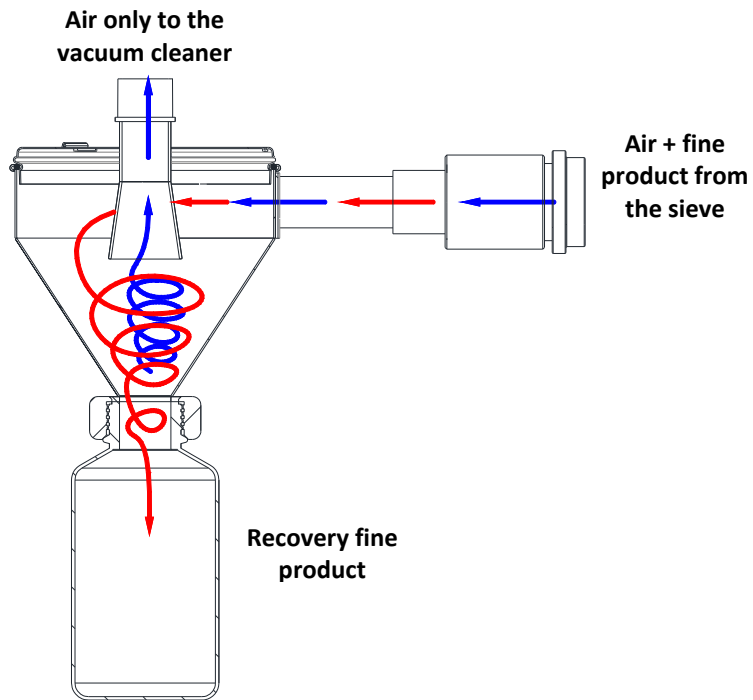

Mounting the cyclon

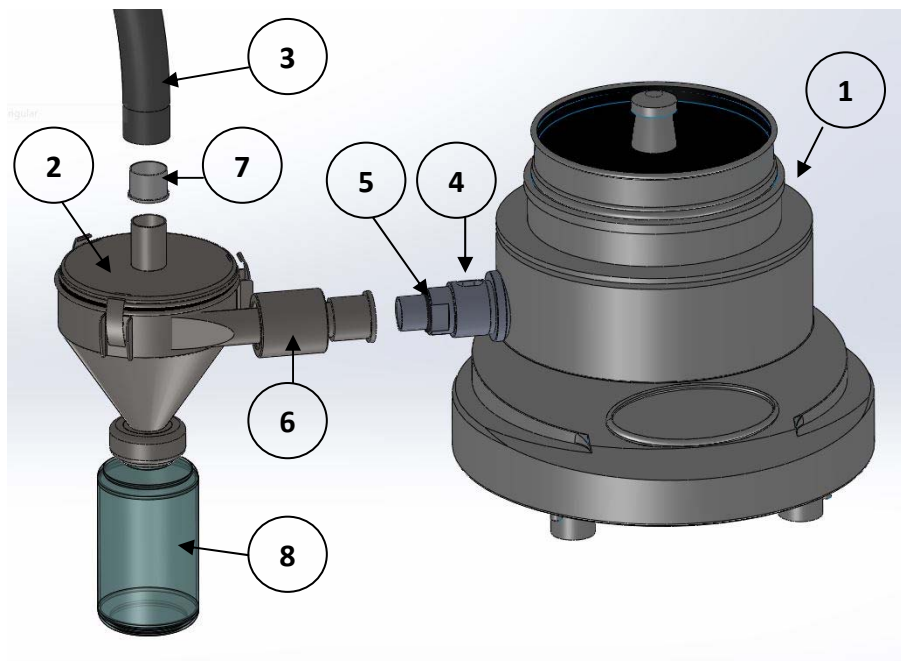

To connect the cyclone 2 to the sieve 1, the horizontal tube must be inserted into the O-ring 5 (make sure it is correctly positioned) and screw the sleeve 6 into the thread of the sieve 4, holding the cyclone and ensuring that the collector bottle 8 is in upright position. Then the bush 7 will be placed in the cyclone cover and the vacuum cleaner tube 3.

For a proper operation it is important that both the cyclone and sifter connection with the gasket 5, and the connection with the vacuum cleaner tube with the sleeve 7 are watertight